

**Features**

- Built-in 100v/70v transformer
- Waterproof projector type loudspeaker
- Supreme longer distance dispersion horn speaker
- Power taps 15W, 30W @100V
- Aluminum enclosure and aluminum bracket

**Description**

The T-720X is a waterproof horn speaker built-in 70v/100v transformer. The 70v/100v transformer technique reduces line losses on longer distance and allows easy parallel connection of multiple loudspeakers.

The built-in horn speaker driver is designed of wide frequency response 300-13KHz, the multiple power taps 7.5W & 15W are helpful for different applications varies from room size and ambient noise surroundings.

The aluminum enclosure and aluminum bracket are of red color. Easy and secure wall mount installation through the supplied mounting bracket.

It is ideal choice for industrial and commercial applications in the outdoor area of parking, park, garden, corridor and playground where paging is needed.



**Specification**

Model	T-720X
Power @100V	15W, 30W
Power @70V	7.5W, 15W
Impedance	Black:COM, Green: 670Ω, White:330Ω
Frequency Response	300-13KHz
SPL(1W/1M)	102dB±3dB
Finish	Baffle: Aluminum, Red
Dimension	247 x 247 x 290mm
Weight	2.1Kg
Mounting	With mounting bracket fixed by screw

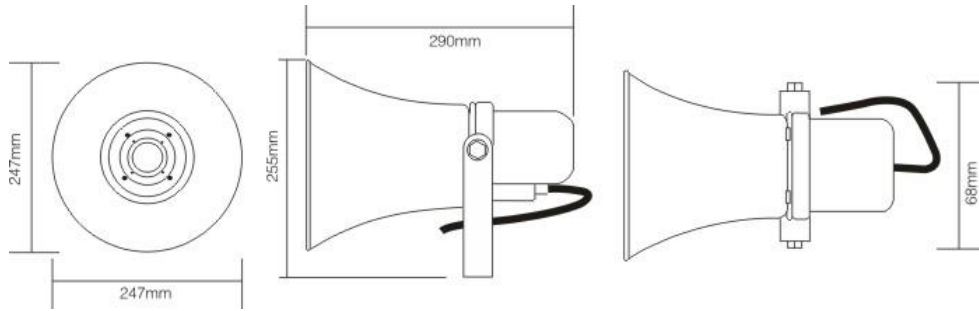
Appearance:

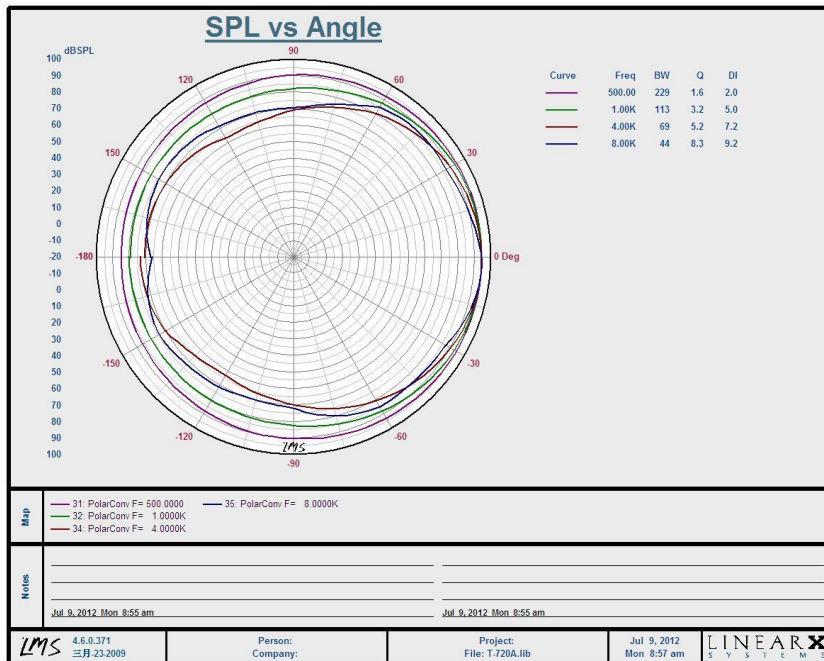

Direction Diagram:



Frequency Response:

